

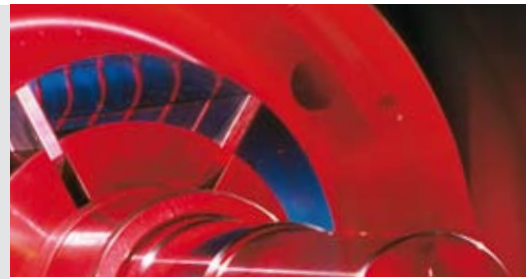

X-Series Systems



Vacuum and pressure for the glass industry



WITTIG Rotary Vanes

When producing the hollow glassware large volumes of compressed air and vacuum are required. High quality and reliability of all units and components is of prime importance, because equipment failure during production invariably means extremely high costs. For continuous 24-hour operation, rotary vane compressors and vacuum pumps offer the best solution.

Compressed air is used to form the blanks in the production machines. A compressed air system is needed to control the various shaping devices and the general air supply of the factory.

Rotary vane vacuum pumps are used to evacuate the glass moulds. This ensures high product quality and increasing the number of pieces per hour poses no problem. Keeping operating costs low is of prime importance. Rotary vane vacuum pumps are the only technology to deliver maximum availability.

For higher volumes vacuum pumping stations are used. These two-stage systems consist of a rotary lobe and rotary vane vacuum pump and are used for the production of electric light bulbs and fluorescent tubes.

- Comprehensive logistics
- On-time delivery
- Quick response times
- Designed and manufactured in Germany



Performance

Pressure

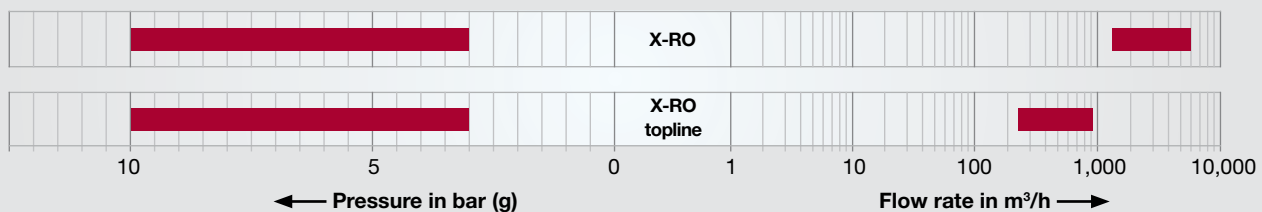

Vacuum

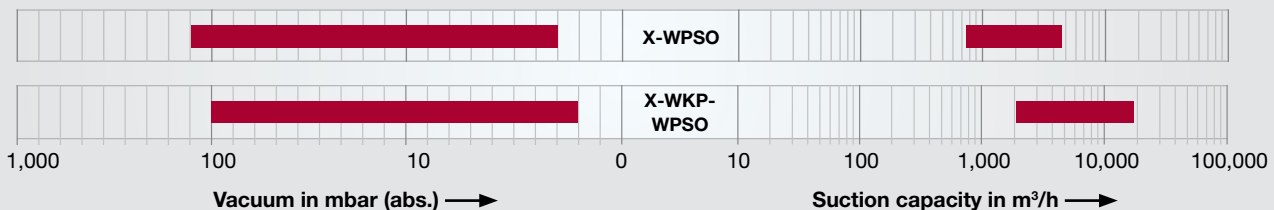

Vacuum & Pressure



X-RO & X-RO topline WITTIG

- Low maintenance
- Low pulsation
- Little oil carry over
- Low life-cycle costs
- Available with microprocessor monitoring and control systems
- Microprocessor control
Wittig MPC 3010 as standard

X-WPSO WITTIG

- Reliable and economical
- Low maintenance
- Easy to service
- Robust construction
- Few moving parts
- Microprocessor control
Wittig MPC 3010 as standard

X-WKP-WPSO WITTIG

- Low power consumption
- Small footprint
- Low purchase costs

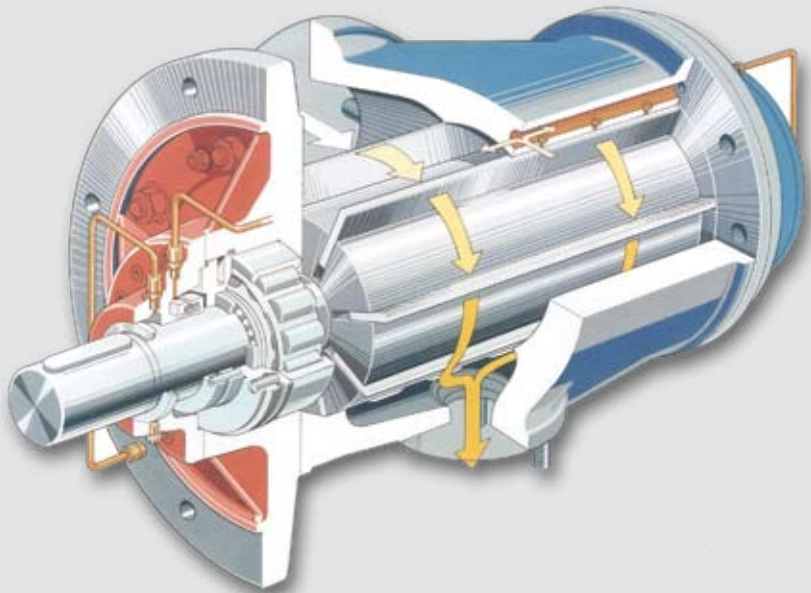

**Gardner
Denver**

Elmo Rietschle is a brand of the
Gardner Denver Blower Division

Gardner Denver Schopfheim GmbH

Roggenbachstraße 58
79650 Schopfheim · Germany

Ph. +49 7622 392-0

Fax +49 7622 392-300

www.gdwittig.de · er.de@gardnerdenver.com